

Index du dossier de réception d'une homologation par type en application d'un Règlement  
*Index to the information package of a type approval with regard to a Regulation*

Dernière Série d'amendements applicable <i>Last applicable Series of amendments</i>	N° de la réception de base et mise à jour <i>Base approval and update No</i>	Extension N° <i>Extension No</i>	Révision N° <i>Revision No</i>	Date d'émission <i>Issue date</i>	Fiche de renseignements <i>Information document</i>	
					Référence <i>Reference</i>	Nombre de pages <i>Number of pages</i>
65-00	00	-	-	08.10.2012	JULUEN B14 TB1 / 515 / 00	5

Vu pour être annexé à la fiche de réception,  
*Approved and to be attached to the approval certificate,*  
L'Attaché,  
*The Attache,*



ir. A. DESCAMPS

N° d'homologation mis à jour : <i>Updated Approval No</i>	E6-65R-000037	BEVASYS :	201207358
Mise à jour n° : <i>Update No</i>	00	Date d'émission : <i>Issue date</i>	08.10.2012
		P 1	



**COMMUNICATION CONCERNANT L'HOMOLOGATION D'UN TYPE DE FEUX-SPECIAL D'AVERTISSEMENT**  
*COMMUNICATION CONCERNING THE APPROVAL GRANTED OF A TYPE OF SPECIAL WARNING LAMP*  
**POUR AUTOMOBILES, EN APPLICATION DU RÈGLEMENT No 65-00**  
*FOR MOTOR VEHICLES, PURSUANT TO REGULATION No. 65-00*

**N° d'homologation :** E6-65R-000037  
*Approval No.*

**Marque d'homologation :**  
*Approval mark*



1. Feu spécial d'avertissement / ~~tournant~~ / à éclat stationnaire / ~~a éclat directionnel rampe complète~~ / de couleur bleue / ~~de couleur jaune auto / rouge~~<sup>1</sup>
1. *Special warning lamp / ~~rotating~~ / stationary flashing lamp / ~~directional flashing lamp / complete bar~~ / blue / ~~amber / red~~*<sup>1</sup>
2. Le feu spécial d'avertissement a un / ~~deux~~ niveaux d'intensité<sup>1</sup>
2. *Special warning lamp has one/ ~~two~~ levels of intensity*<sup>1</sup>  
Le feu spécial d'avertissement est composé de ... unités distinctes...  
*Special warning lamp consists of ..... separate units.*
3. Pour les feux spéciaux d'avertissement ayant deux niveaux d'intensité système employé pour obtenir une intensité renforcée de jour : -
3. *For special warning lamps having two levels of intensity, indicate the system used to obtain increased intensity at daytime :*
4. Source lumineuse utilisée,
4. *Used light source,*
  - ~~Catégorie de lampe à incandescence~~ ou ;  
*category of filament lamp* or ;
  - ~~Source lumineuse à décharge...~~ ou ;  
*gas discharge light source* or ;
  - Source lumineuse à DEL oui / ~~non~~<sup>1</sup> ou ;  
*LED* yes / ~~no~~<sup>1</sup> or ;
  - 10LEDs / 1 light source
  - Module d'éclairage : ~~oui~~ / non<sup>1</sup>
  - Light source module: yes / no<sup>1</sup>
  - Code d'identification spécifique du module d'éclairage :-  
*Light source module specific identification code:*
5. Tension nominale de feu spécial d'avertissement : 12V 42W / 24V 42W
5. *Rated voltage of special warning lamp :*
6. Marque ou désignation commerciale : AXIXTECH ; AEB BELGIUM
6. *Trade name or mark :*

<sup>1</sup> Biffer les mentions qui ne conviennent pas - *Strike out what does not apply*

7. Nom et adresse du fabricant:  
7. *Manufacturer's name and address :*
- JULUEN ENTERPRISE CO., LTD.  
8F-1, No. 502, Da An Rd. Shulin District  
Xinbei City, Taiwan
8. Le cas échéant, nom et adresse du représentant du fabricant : -  
8. *If applicable, name and address of manufacturer's representative : .*
9. Présenté à l'homologation le: 11.09.2012 ~ 25.09.2012  
9. *Submitted for approval on :*
10. Service technique chargé des essais d'homologation:  
10. *Technical service responsible for approval tests :*
- AIB VINCOTTE INTERNATIONAL  
Jan Olieslagerslaan 35  
1800 VILVOORDE
11. Date du procès-verbal délivré par ce service : 08.10.2012  
11. *Date of report issued by that service :*
12. Numéro du procès –verbal délivré par ce service : H1260347978/195  
12. *Number of report issued by that service :*
13. L'homologation est accordée / étendue<sup>1</sup>  
13. *Approval granted / ~~extended~~<sup>1</sup>*
14. Motif (s) de l'extension (le cas échéant) : -  
14. *Reason(s) of extension (if applicable) :*

15. Lieu : Bruxelles  
15. Place
16. Date : 08.10.2012  
16. Date
17. Signature :  
17. Signature

AU NOM DU MINISTRE :  
*ON BEHALF OF THE MINISTER*  
Pour le Directeur Général,  
*For the Director General*  
L'Attaché,  
*The Attache,*



ir. A. DESCAMPS

18. On trouvera en annexe à la présente communication, la liste des pièces constituant le dossier d'homologation déposé auprès du Service administratif qui a accordé l'homologation; ces pièces peuvent être obtenues sur demande
18. *The list of documents filed with the Administrative Service which has granted approval and available on request is annexed to this communication.*

**AIB-VINÇOTTE International n.v.**

Head office: Diamant Building – A. Reyerslaan 80 – B-1030 Brussels

Company number : BE 0462.513.222 – HRB : 621315 – Internet : [www.vincotte.com](http://www.vincotte.com) Safety, quality and environmental services

ISO/IEC 17020 Accredited inspection body - Accreditation certificate BELAC No. 016-INSP

**AUTOMOTIVE CERTIFICATION**

Business Class Kantorenpark – Jan Olieslagerslaan 35 – B-1800 Vilvoorde

Telephone : +32 (0)2/674.58.85 – Fax : +32 (0)2/674.59.62

E-mail: [homologation@vincotte.be](mailto:homologation@vincotte.be)**1. SUBJECT : SPECIAL WARNING LAMP**

R65-00

2. **REF. :** Report number : **H1260347978/195** No. of pages : 1 of 12 No. of annexes : -  
Bevasys : 201207358 Approval No. : (0037 00) Update : 00

**3. GENERALITIES :**

Make of Device : AXIXTECH ; AEB BELGIUM

Commercial Type : -

Manufacturer's Type : B14 TB1 ; 515

Name and address of the manufacturer :

JULUEN ENTERPRISE CO., LTD.

8F-1, No. 502, Da An Rd. Shulin District

Xinbei City, Taiwan

4. **TESTS :** Date and place : 2012.09.11 to 2012.09.25  
SUN-JET VISIBLE LIGHT LABORATORY

Applied document(s) : JULUEN B14 TB1 / 515 / 00

AVI Inspector : LU WAN-CHING

Persons witnessing the tests : LU WAN-CHING

Location of E-mark : On the lamp

**5. CONCLUSIONS :**

The tests were carried out according to the following specifications :

- UNECE Regulation No. 65 incorporating supplement 7 to the original version.

The models presented comply with the requirements to be applied.

Date : 2012.10.08

Signature :

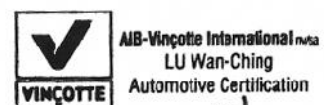

**DESCRIPTION OF THE TESTED HEADLAMP**

Special warning lamp type : ~~rotating~~/stationary flashing lamp/~~directional flashing lamp/ complete bar~~  
 Color : blue/~~amber/red~~  
 Nr of separate units : -  
 Light source : LED  
 Number of light source(s) : 10LEDs / 1 light source  
 Voltage and wattage : 12V 42W / 24V 42W  
 Light source module : ~~Yes~~ / No  
 Light source module specific identification code : -

**GENERAL SPECIFICATIONS**

Characteristics concerned and prescriptions to apply	References	Conformity	Not applied
The special warning lamps must be so designed and constructed that in normal conditions of use, and notwithstanding the vibrations to which they may be subjected in such use, their satisfactory operation remains assured and they retain the characteristics prescribed by this Regulation.	5.1.	X	
The special warning lamps must be so designed and constructed that the relevant requirements with regard to voltage higher than 50 V are fulfilled.			
The special warning lamp shall be so designed that after it has been mounted correctly on the vehicle, no maladjustment is possible.	5.2.	X	
The special warning lamp shall be powered directly from the voltage supply network of the vehicle by direct connection or usual connectors (e.g. cigarette lighter plug).	5.2.1.	X	
When a non-replaceable light source is used it shall be permanently fixed to the special warning lamp.	5.3.	X	
Light source module	5.4.		X
The design of the light source module(s) shall be such that even in darkness the light source module(s) can be fitted in no other position, but the correct one.	5.4.1.		
The light source module(s) shall be tamperproof.	5.4.2.		
In the case of a system that uses a special power supply, or a dedicated power supply, or light source control gear shall be part of special warning lamp.	5.5.		X
The frequency f, the "on" time $t_H$ and the "off" time $t_D$ shall correspond to the values indicated in the table in Annex 5 to this Regulation. They shall be measured at an ambient temperature of $+ 23^{\circ} C \pm 5^{\circ} C$ and with voltages at the terminals of the device which are between 90 per cent and 115 per cent of the rated voltage. Moreover, starting and correct functioning of the special warning lamp shall remain assured at temperatures between $- 20^{\circ} C$ and $+ 50^{\circ} C$ or if the special warning lamp is exposed to heavy rain, in accordance with the procedure described in Annex 4 to this Regulation. Under those conditions, one minute after a voltage equal to 90 per cent of the rated voltage has been applied, the frequency shall remain between 2 and 4 Hz.	5.6.	X	

Characteristics concerned and prescriptions to apply	References	Conformity	Not applicated
A rotating or flashing special warning lamp device of Category T may consist of more than one optical system. In this case the requirements of Annex 5 § 8 must be met. The lamp manufacturer must supply mounting information to ensure that the various units are correctly mounted on a vehicle.	5.7.		X

**PHOTOMETRIC SPECIFICATIONS**

Characteristics concerned and prescriptions to apply	References	Conformity	Not applicated
The special warning lamps shall comply with the conditions prescribed in Annex 5 to this Regulation.	6.	X	

**CHECKING THE COLOUR OF THE SPECIAL WARNING LAMP**

Characteristics concerned and prescriptions to apply	References	Conformity	Not applicated
<p>The colour shall comply with the colorimetric boundaries prescribed in Annex 3 to this Regulation.</p> <p>The colorimetric characteristics of the light emitted, expressed in CIE chromaticity co-ordinates, shall be evaluated using the light source as designed, working at the voltage as specified in § 4.2. in Annex 5 of this Regulation.</p> <p>In case of a special warning lamp employing a Xenon flash tube, as an alternative the chromaticity co-ordinates may be deduced from the spectral distribution of the transmission of the cover and the transmission or reflection of any other optical effective elements which could impair the colour of the special warning lamp. The calculation then shall be based on a luminous source with a relative spectral distribution as listed in Annex 6.</p>		X	

**TRICHROMATIC CO-ORDINATES FOR THE LIGHT EMITTED THROUGH THE AMBER OR BLUE FILTERS CONSTITUTING THE COVERS OF SPECIAL WARNING LAMPS (ANNEX 3)**

Characteristics concerned and prescriptions to apply	References	Conformity	Not applied
<p>Under the conditions of § 7 of this Regulation, the trichromatic co-ordinates of light emitted through the filters used for special warning lamps shall lie within the following boundaries:</p> <p>1. Amber <sup>1</sup></p> <p>    limit towards green : <math>y \leq x - 0.120</math></p> <p>    limit towards red : <math>y \geq 0.390</math></p> <p>    limit towards white : <math>y \geq 0.790 - 0.670 x</math></p> <p>2. Blue</p> <p>    limit towards green : <math>y = 0.065 + 0.805 x</math></p> <p>    limit towards white : <math>y = 0.400 - x</math></p> <p>    limit towards purple : <math>y = 1.67x - 0.222</math></p> <p>3. Red</p> <p>    limit towards purple : <math>y \geq 0.980 - x</math></p> <p>    limit towards yellow : <math>y \leq 0.335</math></p>		<p>X</p>	<p>X</p>

<sup>1</sup> Corresponds to a specific part of the "yellow" zone of the triangle of CIE colours.



**PROCEDURE FOR THE RAIN TEST (ANNEX 4)**

Characteristics concerned and prescriptions to apply	References	Conformity	Not applied
<p>A sample of the special warning lamp, fitted in its normal operating position, with all the drainage apertures open if they exist, shall be subjected to a precipitation of 2.5 mm of water per minute, the water being directed at an angle of 45° and from a nozzle producing a full conical jet.</p> <p>During the test, the device shall turn on its vertical axis at a rate of 4 turns per minute.</p> <p>The test shall last for 12 hours continuously after which the water jet shall be stopped.</p> <p>One hour later, the sample shall be examined and shall be regarded as having passed the test if the accumulated volume of water does not exceed 2 cm<sup>3</sup>.</p>		X	

**PHOTOMETRIC SPECIFICATIONS (ANNEX 5)**

Characteristics concerned and prescriptions to apply	References	Conformity	Not applied
<p>Measurements of the photometric characteristics shall be taken at a distance of at least 25 m.</p> <p>The angular diameter of the photoelectric receiver as seen from the special warning lamp shall be 10 minutes or arc maximum.</p> <p>The response time of the photometric system shall be adequate to the rising time of the signal to be measured.</p>	1.	X	
<p>For special warning lamps having one level of intensity (class1), the "by night" level shall apply.</p> <p>For special warning lamps having two levels of intensity (class 2), measurements shall be carried out for each of the two levels.</p> <p>The effective luminous intensities in various directions shall be as specified in the table below.</p>	2.	X	

Characteristics concerned and prescriptions to apply	References	Conformity	Not applied
<p>If a filament lamp is used that shall be a standard filament lamp as provided for in Regulation No. 37 corresponding to a lamp of the category specified for the special warning lamp.</p>	3.		X
<p>Light source conditions for test:</p>	4.		
<p>In the case of replaceable light sources a standard lamp shall be used.</p>	4.1.		X
<p>All measurements on lamps equipped with replaceable or non-replaceable light sources (filament lamps, gas discharge light sources and other) shall be made at 6.75 V, 13.5 V or 28.0 V, respectively.</p>	4.2.	X	
<p>In the case of a system that uses a special power supply, or a dedicated power supply, or light source control gear, the voltage declared by the manufacturer shall be applied to the input terminals of that power supply. Unless otherwise specified 6.75 V, 13.5 V or 28 V, as applicable shall be used.</p>			
<p>In the case of filament lamps it is allowed to make the measurements with a standard filament lamp at reference flux conditions nearly at 12 V and recalculate the measured values by a factor, which is determined with this standard filament lamp at 13.5 Volt, if applicable.</p>	4.3.		X
<p>For any lamp equipped with non-filament light source(s), the luminous intensities measured after one minute and after 30 minutes of operation shall comply with the minimum and maximum requirements. The luminous intensity distribution after one minute of operation can be calculated by applying the ratio achieved at HV between one minute and 30 minutes of operation.</p>	5.	X	
<p>If the emitted light of a special warning lamp consists of groups of several flashes, the time distance <math>\Delta t</math> between the immediately following flashes must be very short.</p>	6.	X	
<p>If the peak to peak distance <math>\Delta t</math> is less or equal to 0.04 s, then the pulses in between are evaluated as one flash. If this distance <math>\Delta t</math> is longer only the flash with the highest effective intensity is valid. Moreover, the period is limited depending on the ratio between the effective intensities of the flashes within a group (IH= max. effective intensity of the highest peak, IL = max. effective intensity of the lowest peak) as follows:</p>			
<p>in case</p> $\frac{I_H}{I_L} > 10 \text{ then } \Delta_t (s) < \frac{1}{3f}$			
<p>in case</p> $1 < \frac{I_H}{I_L} < 10 \text{ then } \Delta_t (s) < \frac{1}{f(5.50 - 0.25 \frac{I_H}{I_L})}$			

Characteristics concerned and prescriptions to apply	References	Conformity	Not applied
<p>Frequency, time, and intensity of the emitted light</p>	7.		
<p>The frequency, the "ON" time and the "OFF" time shall be as specified in the table shown in §7.1</p>	7.1	X	
<p>The effective luminous intensities (<math>J_e</math>) within the relevant vertical angles for a special warning lamp (Category T) shall be as specified in the table shown in §7.2.</p>	7.2.	X	
<p>In the case of a special warning lamp device which is comprised of more than one separate unit, the geometrical arrangement(s) as installed at the vehicle seems to be acceptable, if the partial light distribution of each single separate unit is overlapping with each adjacent partial light distribution inside a horizontal angular range of 360° and in a vertical angular range as specified for the relevant category in a geometrical position corresponding to a distance of 20 m, from the vehicle on a vertical plane that is perpendicular to the longitudinal axis of the vehicle and located midway between the lamp units on a side of the vehicle.</p>	7.2.1.	X	
<p>The effective luminous intensities in the reference axis for a directional flashing lamp (Category X) shall be as specified in the table shown in §7.3.</p>	7.3.		X
<p>Table of standard light distribution for special warning flash lamp (Category X)</p>	7.3.1.		
<p>Minimum horizontal angular range of category "narrow angle effect" is 30° left to 30° right and for category "wide angle effect" 90° directed outwards the vehicle and 30° to the inside.</p>			
<p>The direction <math>H = 0^\circ</math> and <math>V = 0^\circ</math> corresponds to the reference axis. (On the vehicle it is horizontal, parallel to the median longitudinal plane of the vehicle and oriented in the required direction of visibility). It passes through the centre of reference. The values shown in the table give, for the various directions of measurements, the minimum intensities as a percentage of the minimum required in the axis for each lamp (in the direction <math>H = 0^\circ</math> and <math>V = 0^\circ</math>).</p>	7.3.1.1.		
<p>Within the field of light distribution of § 7.3.1. schematically shown as a grid, the light pattern should be substantially uniform, i.e. the light intensity in each direction of lowest minimum value being shown on the grid lines surrounding the questioned direction as a percentage.</p>	7.3.1.2.		
<p>In the case of a special warning lamp device of Category X which comprises of more than one separate unit, the geometrical arrangement(s) as installed on the vehicle, is(are) acceptable when the partial light distribution of each single separate unit is overlapping with each adjacent partial light distribution inside the horizontal and vertical angular range specified for the Category X.</p>	7.3.2.		

Characteristics concerned and prescriptions to apply	References	Conformity	Not applied
<p>If two or more optical systems are integrated in one special warning lamp, this unit has to comply with the following requirements:</p> <p>Each optical system shall be in accordance with the requirements of this Annex within the horizontal angle which is not covered by one of the other optical systems. Furthermore, in each required direction at least one optical system shall be effective corresponding to the requirements of this Annex.</p> <p>If a special warning lamp contains two or more optical systems, all the optical systems shall work in phase. This applies only to each half of a complete "bar" which is designed to extend on the width of the vehicle.</p> <p>As long as the efficiency of the special warning lamp is to be secured all around the car a detection of the failure of a part of a special warning system shall exist on the car. If it is designed by the special warning lamp manufacturer this detection shall be checked during the approval procedure.</p>	<p>8.</p> <p>8.1.</p> <p>8.2.</p> <p>8.3.</p>		X

**FACILITIES AND EQUIPMENT**

The facilities and equipment used to carry out the inspections are in compliance with the requirements of the applied Regulatory Act(s).

Equipment Description	Model Number
SJTC-O-001 Goniophotometer	OPTRONIK SMS 10c
SJTC-O-016 Flash meter	Czibula & Grundmann GmbH Ph-St-B8-Th-Fast
SJTC-O-017 High-Speed Multi Channel Spectrophoto Meter	OTSUKA MCPD-9800(2480)
SJTC-O-011 Power Supply	OPTRONIK SNT10
SJTC-O-021 Oscilloscope	TEKTRONIX DPO3012
SJTC-M-005 Aging Oven Tester	GOLDEN TOP
SJTC-M-015 Temperature & Humidity Tester	GIANT FORCE
Rain Test	TESTING BY JULUEN ENTERPRISE CO., LTD.

**TEST RESULTS : For Special Warning Lamp on By Night Level**

Light sources : 10LEDs / 1 light source ; Rated voltage and wattage : 12V 42W / 24V 42W

Specification : Measure the effective luminous intensity  $J_e$ , locating minimum and maximum value along horizontal plane, 10 degree increments.

**Test Results of Photometric Measurement and Flash Characteristics Measurement**

Lamp Function	: Blue Special Warning Lamp	Test Voltage	: 13.5V / 28V
Category & Class	: TB1	Test Distance	: 25 m
Requirement	: ECE Reg. 65 Annex 5		
By Day / By Night	: By Night	“ON” time $t_H$	: 0.1931 s / 0.1935 s
Frequency (f)	: 2.06 Hz / 2.05 Hz	“OFF” time $t_D$	: 0.2924 s / 0.2928 s
Flash Mode	: Double Flash		

Point on Measuring Screen	Requirement(cd)		Measurement (cd)					
			Sample 1 (12V)			Sample 2 (24V)		
	Min	Max	1 Minute	30 Minutes	Remark	1 Minute	30 Minutes	Remark
H - 180R(L)	50	700	52.7	52.3		54.8	55.0	
H - 170R	50	700	51.0	50.7		54.5	54.7	
H - 160R	50	700	51.4	51.1		54.6	54.9	
H - 150R	50	700	50.9	50.6	Min. $J_e$	52.7	53.0	
H - 140R	50	700	53.6	53.3		51.7	51.9	
H - 130R	50	700	52.6	52.3		50.5	50.8	
H - 120R	50	700	52.9	52.6		51.7	51.9	
H - 110R	50	700	55.4	55.1		50.9	51.1	
H - 100R	50	700	53.4	53.1		52.0	52.2	
H - 90R	50	700	52.0	51.7		53.2	53.4	
H - 80R	50	700	52.3	52.0		53.7	53.9	
H - 70R	50	700	53.9	53.6		50.3	50.5	
H - 60R	50	700	56.5	56.2	Max. $J_e$	52.9	53.1	
H - 50R	50	700	54.0	53.7		52.2	52.4	
H - 40R	50	700	51.2	50.9		51.2	51.4	
H - 30R	50	700	52.6	52.3		51.8	52.0	
H - 20R	50	700	51.1	50.8		53.0	53.2	
H - 10R	50	700	51.2	50.9		51.9	52.1	
H - V	50	700	54.5	54.2		53.7	54.0	
H - 10L	50	700	54.0	53.7		52.8	53.0	
H - 20L	50	700	54.2	53.9		52.2	52.4	
H - 30L	50	700	53.9	53.5		50.4	50.6	
H - 40L	50	700	52.6	52.3		50.4	50.6	
H - 50L	50	700	51.1	50.8		50.6	50.8	
H - 60L	50	700	51.5	51.2		50.8	51.0	
H - 70L	50	700	51.3	51.0		50.1	50.3	
H - 80L	50	700	52.4	52.1		51.0	51.2	
H - 90L	50	700	53.9	53.6		50.0	50.2	Min. $J_e$
H - 100L	50	700	53.9	53.5		51.2	51.4	
H - 110L	50	700	53.0	52.7		50.8	51.0	
H - 120L	50	700	51.3	51.0		53.5	53.7	
H - 130L	50	700	54.5	54.1		52.5	52.7	
H - 140L	50	700	53.3	53.0		52.4	52.6	
H - 150L	50	700	53.1	52.8		54.5	54.8	Max. $J_e$
H - 160L	50	700	53.4	53.1		53.2	53.4	
H - 170L	50	700	53.9	53.6		51.9	52.2	

Test Results

Passed

Failed

**Test Results of Photometric and Flash Characteristics Measurement**

Lamp Function	: Blue Special Warning Lamp	Test Voltage	: 13.5 / 28 V
Category&Class	: TB1	Test Distance	: 25 m
Requirement	: ECE Reg. 65 Annex 5 and Annex 3		
By Day / By Night	: By Night	“ON” time $t_H$	: 0.1931 s / 0.1935 s
Frequency (f)	: 2.06 Hz / 2.05 Hz	“OFF” time $t_D$	: 0.2924 s / 0.2928 s
Flash Mode	: Double Flash		

**Test Results of Photometric Measurement**

Point on Measuring Screen	Requirement ( cd )		Sample 1 (12V) Je Measurement ( cd )			
	Min	Max	Locating Maximum Je		Locating Minimum Je	
			1 Minute	30 Minutes	1 Minute	30 Minutes
4U - 60R	25	600	63.2	60.4	-	-
2U - 60R	-	700	60.3	57.6	-	-
H - 60R	50	700	58.8	56.2	-	-
2D - 60R	-	700	60.9	58.1	-	-
4D - 60R	25	600	62.6	59.8	-	-
Outside the above areas	-	300	33.0	31.5	-	-
4U - 150R	25	600	-	-	49.4	47.1
2U - 150R	-	700	-	-	56.0	53.5
H - 150R	50	700	-	-	53.0	50.6
2D - 150R	-	700	-	-	53.0	50.6
4D - 150R	25	600	-	-	48.3	46.2
Outside the above areas	-	300	-	-	29.5	28.2
Point on Measuring Screen	Requirement ( cd )		Sample 2 (24V) Je Measurement ( cd )			
	Min	Max	Locating Maximum Je		Locating Minimum Je	
			1 Minute	30 Minutes	1 Minute	30 Minutes
4U - 150L	25	600	49.5	49.7	-	-
2U - 150L	-	700	53.9	54.1	-	-
H - 150L	50	700	54.5	54.8	-	-
2D - 150L	-	700	50.7	50.9	-	-
4D - 150L	25	600	49.7	49.9	-	-
Outside the above areas	-	300	33.6	33.7	-	-
4U - 90L	25	600	-	-	47.9	48.1
2U - 90L	-	700	-	-	48.9	49.1
H - 90L	50	700	-	-	50.0	50.2
2D - 90L	-	700	-	-	48.4	48.6
4D - 90L	25	600	-	-	47.4	47.6
Outside the above areas	-	300	-	-	32.4	32.5
Test Results	<input checked="" type="checkbox"/> Passed		<input type="checkbox"/> Failed			

**Test Results of Colour Measurement**

Light Emitted Color : Blue  
 By Day / By Night : By Night  
 Color Boundaries - Limit towards green :  $y = 0.065 + 0.805 x$   
 - Limit towards white :  $y = 0.400 - x$   
 - Limit towards purple :  $y = 1.667 x - 0.222$

Test Points	Measurement ( x ,y)	
	Sample 1 (12V)	Sample 2 (24V)
Point 1	(0.1419, 0.0416)	(0.1416, 0.0421)
Point 2	(0.1421, 0.0411)	(0.1420, 0.0415)
Point 3	(0.1422, 0.0406)	(0.1420, 0.0412)
Point 4	(0.1421, 0.0408)	(0.1421, 0.0409)
Point 5	(0.1420, 0.0421)	(0.1420, 0.0414)
Test Results	■ Passed	□ Failed

*Sample 1 (12V)- chart*

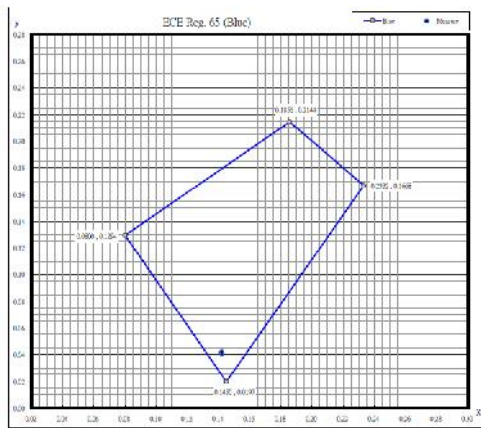

*Sample 2 (24V)- chart*

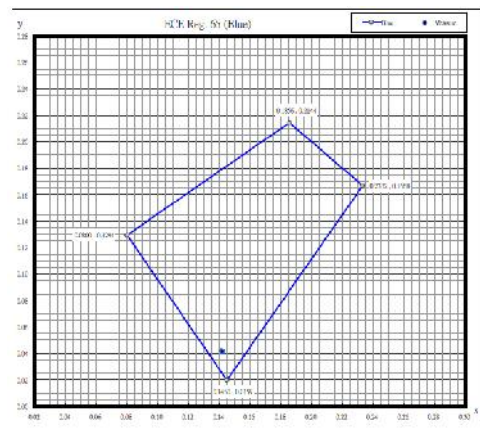

**Test Results of Temperature Measurement**

Lamp Function : Blue Special Warning Lamp

Requirement : ECE Reg. 65 Para 5.6

Test Requirement : The special warning lamp shall remain assured at temperatures between - 20 °C and + 50 °C. Under the condition, one minute after a voltage equal to 90 percent of the rated voltage has been applied, the frequency shall remain between 2 and 4 Hz.

Flash frequency measurement within temperature test :

Test sample	Temperature (°C)	Requirement ( Hz )		Measurement ( Hz )
		Min	Max	
<i>Sample 1</i>	-20	2.0	4.0	2.02
	50			2.04
Test Results	<input checked="" type="checkbox"/> Passed <input type="checkbox"/> Failed			

**Test Results of Rain Test**

Lamp Function : Blue Special Warning Lamp

Requirement : ECE Reg. 65 Annex 4

Visible Inspection : Upon completion of the drain one hour later, the accumulated volume of water does not exceed 2 cm<sup>3</sup>.

Flash frequency measurement within rain test :

Test Sample	Requirement ( Hz )		Measurement ( Hz )
	Min	Max	
<i>Sample 3</i>	2.0	4.0	2.05
Test Results	<input checked="" type="checkbox"/> Passed <input type="checkbox"/> Failed		

(Null below)



ECE INFORMATION DOCUMENT REF: JULUEN B14 TB1 / 515 /00

**JULUEN ENTERPRISE CO., LTD.**  
8F-1, No. 502, Da An Rd. Shulin District,  
Xinbei City, Taiwan



**AUTOMOTIVE** certification  
Business Class Kantorenpark  
Jan Olieslagerslaan 35  
B-1800 Vilvoorde  
E-mail: [homologation@vincotte.be](mailto:homologation@vincotte.be)  
2012.10.08

## **SPECIAL WARNING LAMP**

**AXIXTECH B14 TB1**  
**AEB BELGIUM 515**

**Application: original**  
**Date: September 05, 2012**

**Total number of pages: 5**

ECE INFORMATION DOCUMENT REF: JULUEN B14 TB1 / 515 /00

**Manufacturer name and address: JULUEN ENTERPRISE CO., LTD.**  
**8F-1, No. 502, Da An Rd. Shulin District,**  
**Xinbei City, Taiwan**

**Trade name or mark : AXIXTECH ; AEB BELGIUM**

**Type of device : B14 TB1 ; 515**



**AUTOMOTIVE certification**  
 Business Class Kantorenpark  
 Jan Olieslagerlaan 35  
 B-1800 Vilvoorde  
 E-mail: [homologation@vincotte.be](mailto:homologation@vincotte.be)  
 2012.10.08

## SPECIFICATIONS

**Function-Application-class category lamp and colour**

<b>Trade name or mark</b>		<b>AXIXTECH &amp; AEB BELGIUM</b>
<b>Function</b>		<i>Special warning lamp</i>
<b>ECE Regulation</b>		65-00 Supplement 7
<b>Levels of intensity (Class)</b>		Class 1
<b>Used intensity system</b>	<b>by day</b>	N.A.
	<b>by night</b>	Normal system
<b>Category</b>		<del>Directional</del> / <del>Rotating</del> / Stationary flashing
<b>Number, category and kind of light source(s)</b>		10 LEDs / 1 light source
<b>Voltage and wattage</b>		12V 42W / 24V 42W
<b>Lens</b>	<b>Outer</b>	Blue
	<b>Filter (Inner)</b>	Clear
<b>Colour of light emitted</b>		<del>Amber</del> / <del>Red</del> / Blue

## TECHNICAL DATA

<b>Part</b>		<b>Material</b>	<b>Remark</b>
<b>Lens</b>	<b>Outer</b>	PC (polycarbonate)	Sabic <sup>(1)</sup>
	<b>Filter (Inner)</b>	PC (polycarbonate)	Sabic <sup>(1)</sup>
<b>Reflector</b>		-	-
<b>Housing</b>		PC+ALUMINUM	ADC12

<sup>(1)</sup> The base material of lens: Type number is LEXAN LS2 from Sabic Innovative Plastics.

## MARKING

<b>Marking</b>		<b>Location</b>
<b>Trade name or mark</b>	<b>AXIXTECH &amp; AEB BELGIUM</b>	See drawing
<b>Approval marks</b>	<b>0037</b>	See drawing

A

B

C

D

E

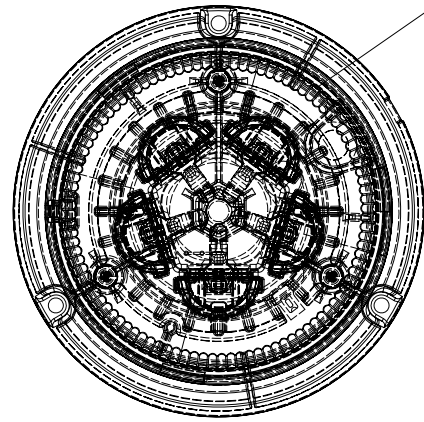

**AXIXTECH** E<sup>6</sup> TB1  
B14 12V/24V 42W 000037

APPROVAL LABEL

TOP VIEW

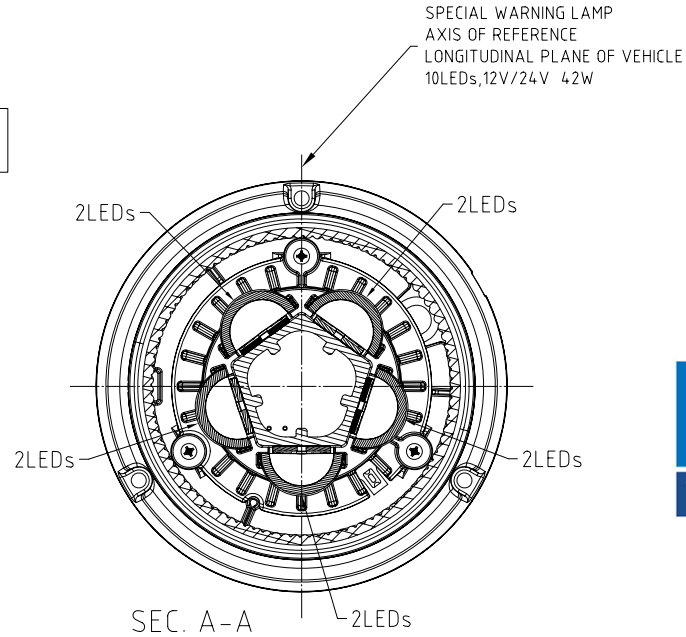

SPECIAL WARNING LAMP  
AXIS OF REFERENCE  
LONGITUDINAL PLANE OF VEHICLE  
10LEDs, 12V/24V 42W

2LEDs

2LEDs

2LEDs

2LEDs

2LEDs

SEC. A-A



**AUTOMOTIVE certification**  
Business Class Kantorenpark  
Jan Olieslagerslaan 35  
B-1800 Vilvoorde  
E-mail: [homologation@vincotte.be](mailto:homologation@vincotte.be)  
2012.10.08

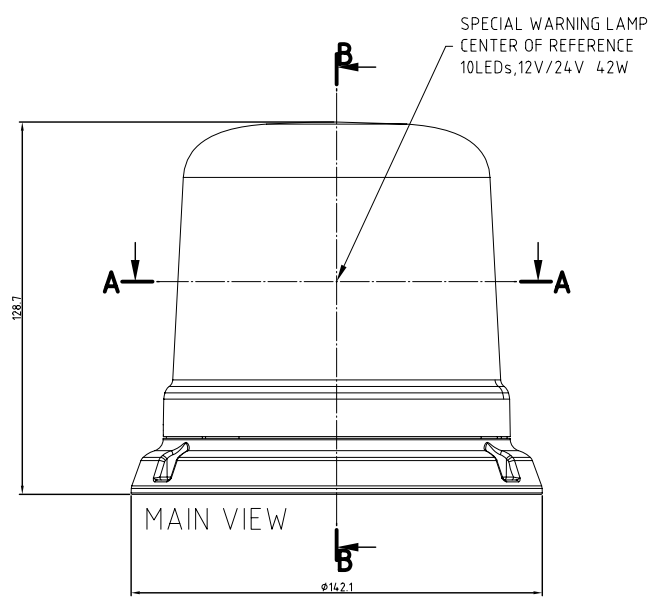

SPECIAL WARNING LAMP  
CENTER OF REFERENCE  
10LEDs, 12V/24V 42W

128.7

MAIN VIEW

ø14.2.1

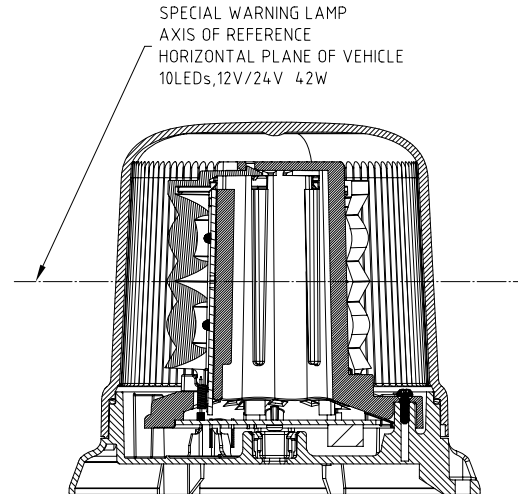

SPECIAL WARNING LAMP  
AXIS OF REFERENCE  
HORIZONTAL PLANE OF VEHICLE  
10LEDs, 12V/24V 42W

SEC. B-B

Note:

1. Lens and Base are secured by snap.
2. Lens and Collimator material (Polycarbonate),  
Base material (Aluminum ADC12 & Polycarbonate)
3. Lens cover color: Blue.



巨輪興業有限公司  
JULUEN Enterprise Co., Ltd.

Ⓢ 重點尺寸

MODEL	B14	TITLE	AXIXTECH(TB1)			
MATERIAL		PR NO.				
APPROVAL		DATE	PROJECTION		Ⓢ	
CHECK		DATE	SCALE	1 : 1	UNIT	mm
DESIGNER	BENNY	DATE	2012/09/21	SHEET	1 / 1	REV
						1.0

1 2 3 4 5 6

A

B

C

D

E

A

B

C

D

E

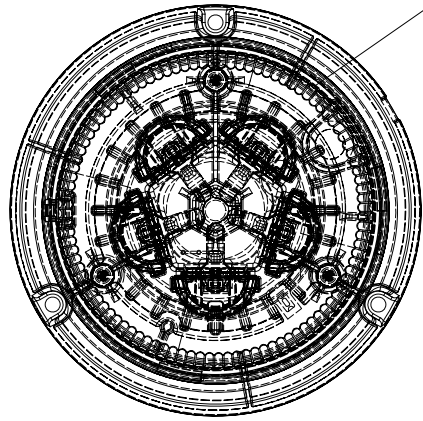

TOP VIEW

**AEB BELGIUM**  **TB1**  
**515 12V/24V 42W** **000037**

APPROVAL LABEL

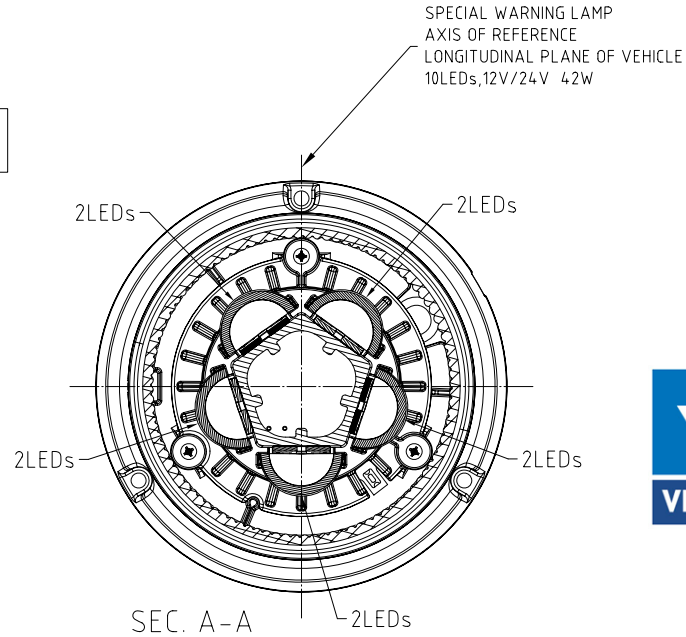

SEC. A-A

SPECIAL WARNING LAMP  
 AXIS OF REFERENCE  
 LONGITUDINAL PLANE OF VEHICLE  
 10LEDs, 12V/24V 42W

2LEDs  
 2LEDs  
 2LEDs  
 2LEDs  
 2LEDs



**AUTOMOTIVE certification**  
 Business Class Kantorenpark  
 Jan Olieslagerslaan 35  
 B-1800 Vilvoorde  
 E-mail: [homologation@vincotte.be](mailto:homologation@vincotte.be)  
 2012.10.08

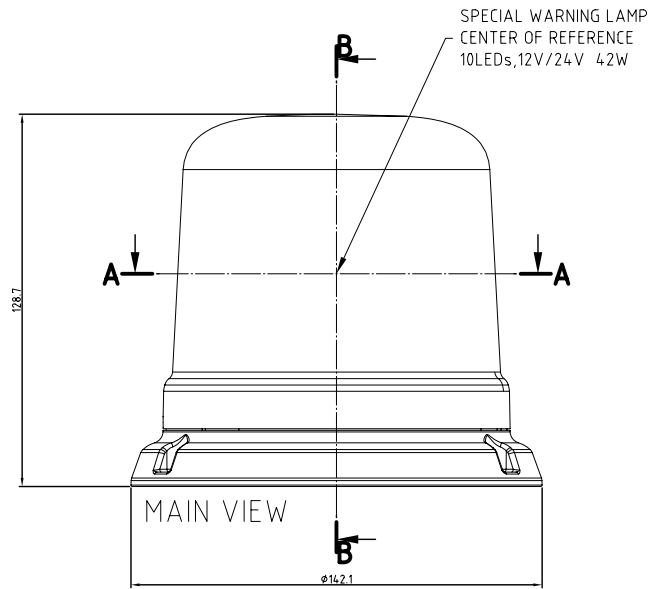

MAIN VIEW

SPECIAL WARNING LAMP  
 CENTER OF REFERENCE  
 10LEDs, 12V/24V 42W

128.7

ø14.2.1

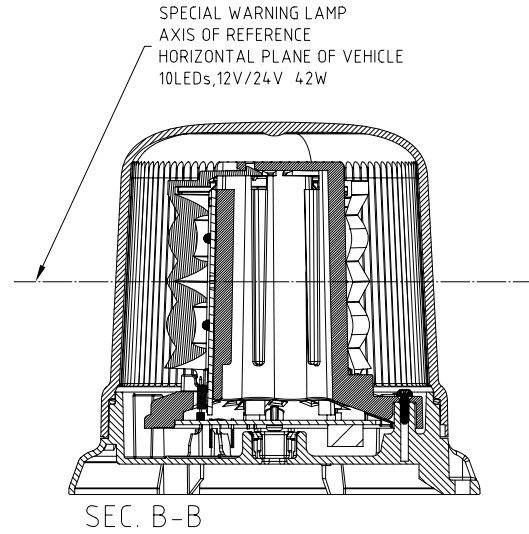

SEC. B-B

SPECIAL WARNING LAMP  
 AXIS OF REFERENCE  
 HORIZONTAL PLANE OF VEHICLE  
 10LEDs, 12V/24V 42W

- Note:
1. Lens and Base are secured by snap.
  2. Lens and Collimator material (Polycarbonate), Base material (Aluminum ADC12 & Polycarbonate)
  3. Lens cover color: Blue.

 **巨輪興業有限公司**  
**JULUEN Enterprise Co., Ltd.**

◎ 重點尺寸	ITEM	MODIFY	DATE	DESIGNER	BENNY	DATE	2012/09/21	SHEET	1 / 1	REV	1.0
	MODEL		B14		TITLE		AEB BELGIUM (TB1)				
	MATERIAL				PR NO.						
	APPROVAL		DATE		PROJECTION						
	CHECK		DATE		SCALE		1 : 1		UNIT		mm

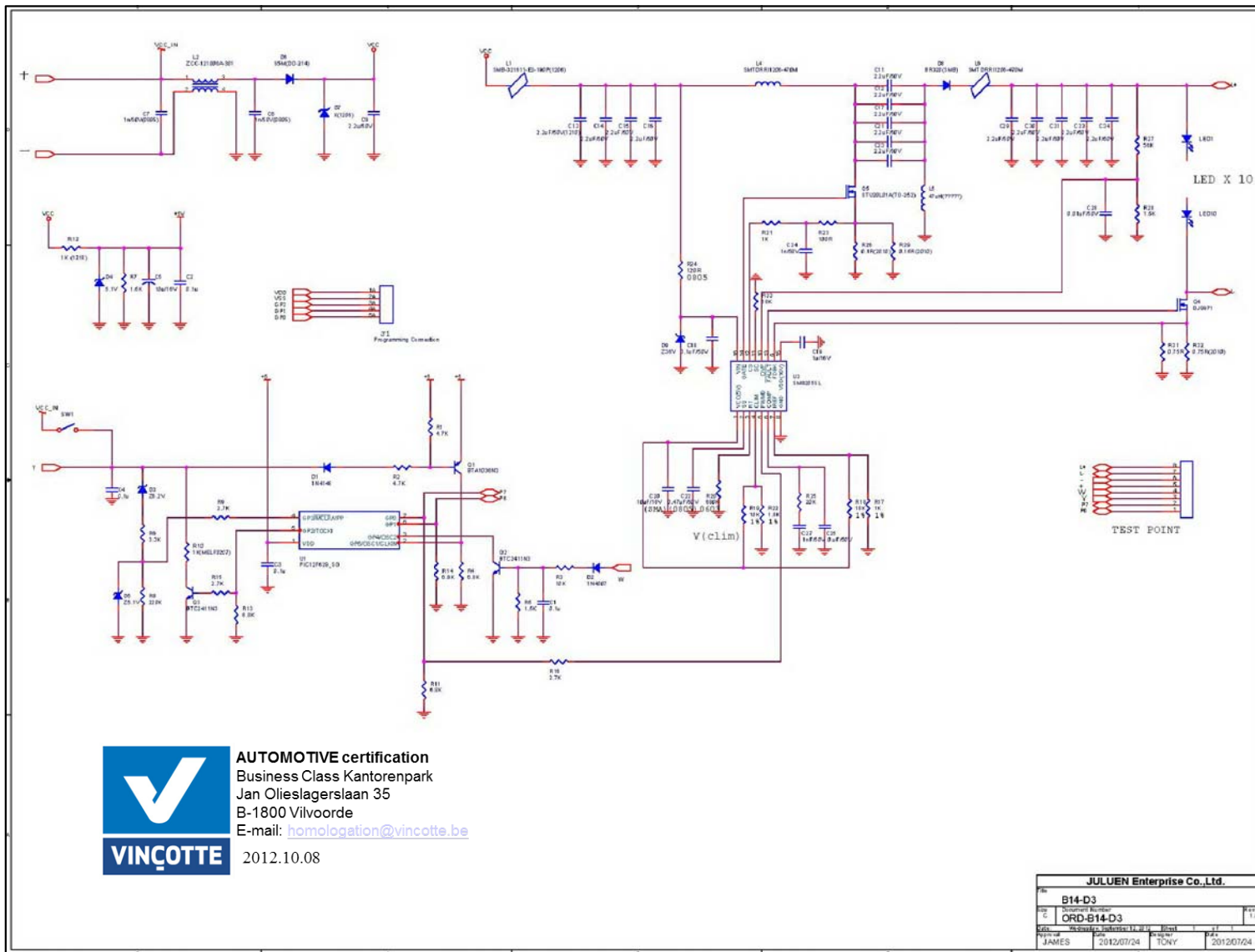

**AUTOMOTIVE certification**  
 Business Class Kantorenpark  
 Jan Olieslagerslaan 35  
 B-1800 Vilvoorde  
 E-mail: [nomologation@vincotte.be](mailto:nomologation@vincotte.be)  
 2012.10.08

JULUEN Enterprise Co., Ltd.			
File	B14-D3		
Code	ORD-B14-D3		
Author	2012/07/24	Checked	2012/07/24
Project	JAMES	Design	TONY

# CIRCUIT DIAGRAM OF SPECIAL WARNING LAMP



巨輪興業有限公司  
 JULUEN Enterprise Co., Ltd.

Ⓢ 重點尺寸

ITEM	MODIFY	DATE

MODEL	B14	TITLE	AXIXTECH(TB1)		
MATERIAL		PR NO.			
APPROVAL		DATE	PROJECTION	⊕	
CHECK		DATE	SCALE	1 : 1	UNIT mm
DESIGNER	BENNY	DATE 2012/09/21	SHEET	1 / 1	REV 1.0